

R&S® CMW500

Wideband Radio Communication Tester

Platform overview



75 Years of
Driving
Innovation

ROHDE & SCHWARZ

R&S®CMW500

Wideband Radio Communication Tester

At a glance

The R&S®CMW500 is the universal tester for testing the air interface of wireless devices. The R&S®CMW500 can be used in all phases of product development and production and supports all common cellular and non-cellular wireless technologies.

All-in-one test platform for wireless devices

The R&S®CMW500 supports and tests all protocol layers – from the RF to end-to-end data. It is based on a concept implementing scalable options and can be adapted to any application.

The R&S®CMW500 can handle the following:

- Wireless standards and broadcast technologies, e.g. LTE (incl. MIMO), WLAN or DVB-T and associated inter-RAT measurements
- All phases of development, verification and production
- All protocol layers, from RF tests and protocol tests to end-to-end application tests
- Module tests, system and integration tests, regression tests, conformance tests and production tests

To adapt the R&S®CMW500 to the requirements of the application, the user simply has to select the appropriate hardware and software components. Rohde & Schwarz offers preconfigured models for a number of important applications.



Modular and flexible hardware

- Max. two independent transmitters and receivers in the frequency range up to 6 GHz, as well as 40 MHz receive bandwidth/80 MHz transmit bandwidth
- No need for external RF switches due to configurable, MIMO-capable RF frontend for flexible connection with wireless devices
- Optional signal processing devices for RF measurements, RF generation and signaling
- Fully automatic path correction versus frequency/time/temperature for top measurement accuracy, plus two-year calibration interval
- Optional digital I/Q interface for connection with fading generators, baseband chips or ASIC emulators
- High-speed non-signaling test concept
- Compact, highly integrated 19" instrument





Application-tailored software

- Vector signal analyzer
- Vector signal generator
- Realtime RRC network emulation and protocol stacks
- U-plane data support for end-to-end performance tests
- Speed-optimized and highly precise measurements for production owing to simultaneous data capturing and evaluation
- Integrated PC and Windows operating system

"WiMAX Forum" is a registered trademark of the WiMAX Forum. "WiMAX," the WiMAX Forum logo, "WiMAX Forum Certified," and the WiMAX Forum Certified logo are trademarks of the WiMAX Forum.

The Bluetooth® word mark and logos are registered trademarks owned by Bluetooth SIG, Inc. and any use of such marks by Rohde & Schwarz is under license.

CDMA2000® is a registered trademark of the Telecommunications Industry Association (TIA - USA).

Platform overview – preconfigured models		
	<p>R&S®CMW500 The all-in-one test platform</p>	<p>The R&S®CMW500 is the universal model for virtually all applications. The R&S®CMW500 offers maximum flexibility – for development and production, for RF and protocol tests as well as for all technologies.</p>
	<p>R&S®CMW280 The compact RF tester for production</p>	<p>The R&S®CMW280 is the compact version of the R&S®CMW500 and has 20% less depth. The instrument can be configured exclusively as a single tester and requires only minimum floor space in classic test concepts.</p>
	<p>R&S®CMW270 The expert for WiMAX™ and non-cellular technologies</p>	<p>Specially designed for the WiMAX™, WLAN, Bluetooth®, GPS, FM radio and broadcast standards, the R&S®CMW270 is a cost-effective alternative for the development and production of equipment outside the conventional cellular networks.</p>
	<p>R&S®CMWPC The R&S®CMW tool set for PC</p>	<p>To maximize the efficiency of the R&S®CMW500 and the R&S®CMW270, any tasks that do not require specialized hardware (e.g. RF converters) can be performed on a PC. The preparation and follow-up of tests or test campaigns or the generation of tests and remote control scripts can be carried out cost-effectively on a standard PC using R&S®CMWPC. R&S®CMWPC is also the basis for virtual protocol testing where the physical layer is replaced by a software emulation.</p>

R&S®CMW500

Wideband Radio Communication Tester

Benefits and key features

Just one 19" box for all technologies

- Support of cellular and non-cellular wireless technologies as well as of broadcast technologies
- (Inter-RAT) handover scenarios with only one tester
- Slim solution for the production of wireless multimode devices

▷ [page 5](#)

Just one 19" box for RF, protocol and application tests

- Increased test depth owing to the combination of protocol and RF measurements
- Early-stage module test with uniform equipment
- Efficient testing of interaction between protocol parameters and application performance

▷ [page 6](#)

Just one 19" box for all product development and production phases

- Consistent measurement results in development, conformance test and production
- Flexible use of instruments across organizational units
- Simple and fast debugging tool
- Shorter time-to-market due to reuse of test scripts and signaling tests

▷ [page 7](#)

Just one scalable hardware

- Future-ready RF parameters
 - Up to two independent RF paths
- Scalable RF resources
- Configurable baseband and signaling units
- Digital I/Q interface

▷ [page 8](#)

Just one reliable T&M partner

- Rohde&Schwarz actively participates in the evolution of the wireless communications standards
- Rohde&Schwarz offers optional services to increase the value of the R&S®CMW500
- Rohde&Schwarz is the leading manufacturer of T&M solutions for wireless standards and provides a complete test portfolio from a single source
- Worldwide sales, application and service network

▷ [page 9](#)

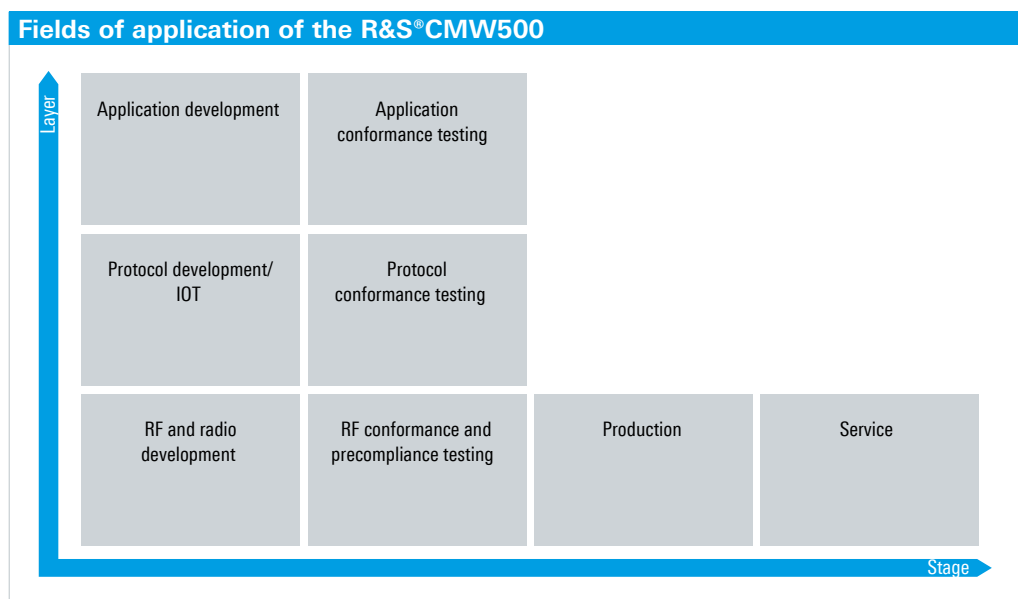

The R&S®CMW500 supports and tests all protocol layers as well as all phases of development, verification and production.

Just one 19" box for all technologies

Support of cellular and non-cellular wireless technologies as well as of broadcast technologies

The R&S®CMW500 is the single-box radiocommunications tester that supports the largest number of technologies. It can handle both the widely used mobile radio standards (e.g. GSM and WCDMA) and new standards such as LTE. To increase the wireless device test depth, it also supports non-cellular standards such as WLAN or Bluetooth® as well as broadcast standards.

This versatility provides many advantages for the user:

- Multimode test setup cabling requires considerably less effort
- The energy consumption of the T&M equipment, especially when used in production, is lower than that of setups involving multiple measuring instruments; the air conditioning requirements are also reduced
- It is much easier to integrate a single tester into automation and remote control systems

(Inter-RAT) handover scenarios with only one tester

The handover capability of a wireless device and especially handover between different technologies can be tested using only one R&S®CMW500 because it already includes all technologies.

Slim solution for the production of wireless multimode devices

The R&S®CMW500 saves space and reduces investment costs both in production and in the lab. Users need only one T&M instrument instead of many. The multichannel capability and the flexible connection with the DUT allow parallel testing of multiple technologies.

Use of the R&S®CMW500 for cellular wireless technologies					
Technology	RF generator	RF analyzer	Network emulation	Protocol test	End-to-end application test
LTE FDD	•	•	•	•	•
LTE TDD (TD-LTE)	•	•	•	•	•
Mobile WiMAX™	•	•	•		•
CDMA2000® 1xRTT	•	•	•		•
CDMA2000® 1xEV-DO	•	•	•		•
TD-SCDMA	•	•			
WCDMA/HSPA+	•	•	•	•	•
GSM/GPRS/EDGE/EDGE Evolution	•	•	•	•	•

Use of the R&S®CMW500 for non-cellular wireless technologies		
Technology	RF generator	RF analyzer
GPS	•	
Bluetooth®	•	•
WLAN a/b/g/n	•	•

Use of the R&S®CMW500 for broadcast technologies	
Technology	RF generator
DVB-T	•
T-DMB	•
MediaFLO™	•
CMMB	•
FM stereo	•

Just one 19" box for RF, protocol and application tests

With regard to technologies such as LTE and HSPA+, the spectrum of measurements and tests spans all protocol layers – from the physical layer to U-plane applications.

Increased test depth owing to the combination of protocol and RF measurements

The parallel measurement of RF parameters during protocol testing speeds up the identification and elimination of errors. For example, the bandwidth used for data or the modulation mode applied are displayed during a protocol test without requiring any additional T&M equipment or complex system setup.

Early-stage module test with uniform equipment

In the early-stage module test, RF and L1, protocol and applications can be tested independently of each other with the same measuring instrument. This reduces the risk that errors will appear later in the subsequent integration phases.

Efficient testing of interaction between protocol parameters and application performance

The IP data throughput and latency can be optimized by selecting appropriate protocol parameters. Measurements of the U-plane performance during the modification of protocol parameters clearly demonstrate how modification impacts the various protocol layers.

Use of the R&S®CMW500 for all tests

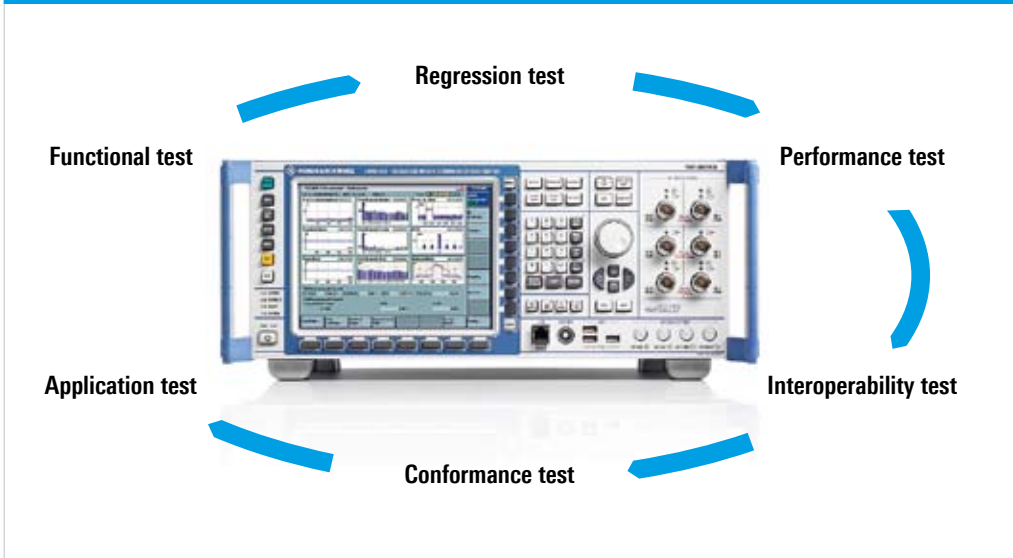

Just one 19" box for all product development and production phases

The R&S®CMW500 is the right solution for all phases of product development and production. The consistent use of the tester in all development and production phases helps to meet schedule and budget requirements.

Consistent measurement results in development, conformance test and production

The use of the R&S®CMW500 during development prevents unpleasant surprises when performing measurements at the production stage. This is because the test methods and boundary conditions have already been applied in earlier phases of product development.

Flexible use of instruments across organizational units

Module developers and integrators use identical T&M equipment. Additional costs and capacity bottlenecks can efficiently be avoided by sharing the instruments among different organizational units.

Simple and fast debugging tool

Users no longer have to familiarize themselves with the operation of various instruments. This increases efficiency of use because even sophisticated measurements can be carried out, utilizing the entire scope of functionalities.

Shorter time-to-market due to reuse of test scripts and signaling tests

Test automation, test scripts or signaling scenarios are developed only once and are reused in the subsequent development stages. The risk involved in new developments is reduced, which in turn cuts the time until product launch.

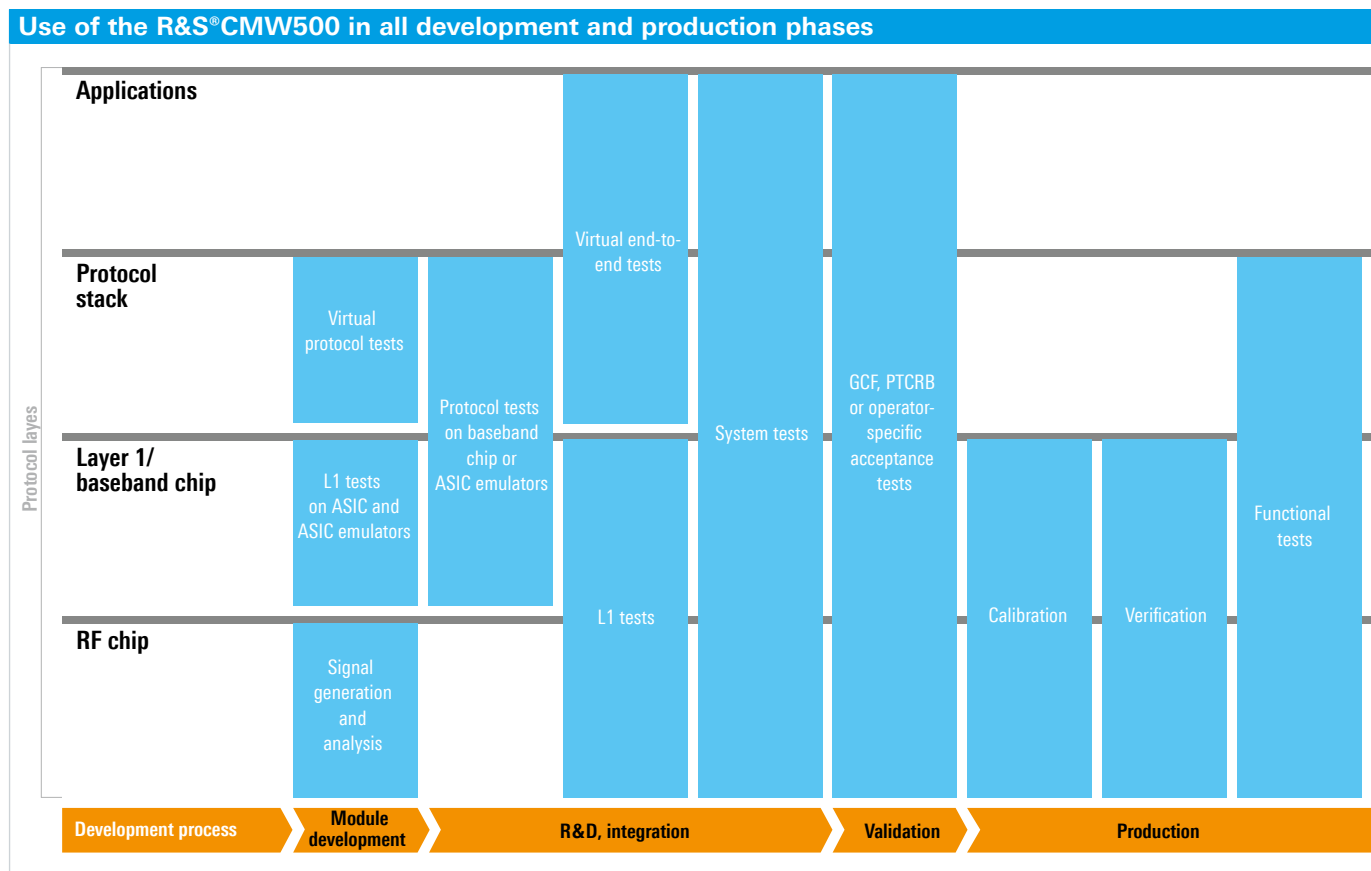

Just one scalable hardware

Future-ready RF parameters

Two independent transmit and receive paths in the frequency range up to 6 GHz and a transmit bandwidth of 80 MHz/receive bandwidth of 40 MHz make the R&S®CMW500 perfect for today's and tomorrow's requirements. A high output dynamic range of 128 dB and sensitive inputs reduce the need for external amplifiers or attenuators.

Scalable RF resources

Depending on the application, one or two RF paths consisting of RF converters and frontends are used. The frontend enables the direct connection of wireless devices with complex RF architecture.

The R&S®CMW500 is therefore fit for the following tests:

- Tests of MIMO-capable DUTs
- Parallel test of two DUTs with the same technology
- Parallel test of two technologies in one DUT

Configurable baseband and signaling units

A maximum of two analyzer modules combined with ARB baseband generators are used in the non-signaling mode. In addition, multiple signaling units can be integrated to provide the network emulation for signaling and protocol tests.

This enables the R&S®CMW500 to emulate complex inter-RAT scenarios¹⁾ – of course in parallel to RF measurements. The ARB¹⁾ can be used for generating interference signals.

Digital I/Q interface

In RF operation, baseband I/Q signals can be used by other equipment via the optional digital I/Q interfaces:

- For fading with the R&S®AMU or R&S®SMU
- For connection with baseband chipsets
- For connection with ASIC emulators

Compatibility with the various I/Q standards can be ensured by using the R&S®EX-IQ-Box digital signal interface module. This module is able to convert the signals to different digital I/Q standards.

¹⁾ For explanations, see glossary at end of brochure.

Block diagram of the R&S®CMW500

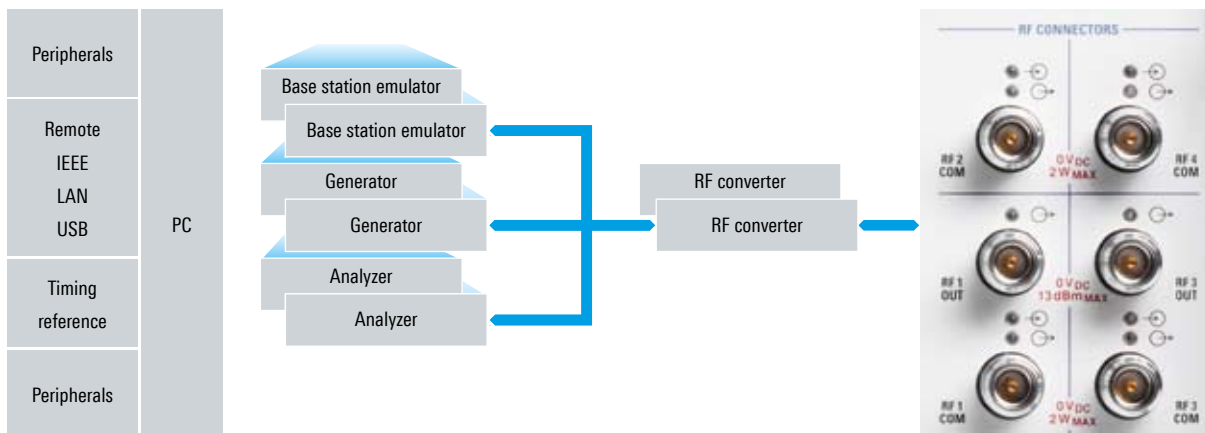

Just one reliable T&M partner

As the leading supplier of T&M equipment for wireless devices, Rohde&Schwarz is actively participating in 3GPP, 3GPP2 and OMA bodies to further develop the communications standards. Standardization results are immediately implemented in the company's T&M equipment, which incorporates decades of experience in wireless communications.

With its dense worldwide support and service network, Rohde&Schwarz helps users to efficiently employ the R&S®CMW500 and achieve maximum benefit and maximum ROI.

Rohde&Schwarz offers the following optional services:

- Calibration and hardware maintenance
- Extended warranty
- Automatic software upgrade services
- Fast, expert technical support by application engineers
- User and technology training

Rohde&Schwarz offers the R&S®CMW500 radiocommunications tester and also additional T&M equipment for wireless devices such as signal generators and signal analyzers. Hardware and software are optimally adapted to each other because they come from a single source.



Application

Production testing

Minimum floor space

- ▮ The R&S®CMW500 can optionally be configured as a dual tester. This configuration includes dual test resources so that two identical wireless devices can be tested simultaneously in the non-signaling mode
- ▮ All wireless technologies are integrated in one instrument

Two different test concepts in one instrument

Signaling

For calibration, the DUT is controlled via an interface, whereas verification is often performed via the network simulation of the wireless communications tester. Especially in the case of new technologies such as LTE, signaling tests are more efficient in the initial production phase because they yield higher test depth and require no additional effort for implementing Test and List modes. For optimizing the test volume, the non-signaling mode is additionally available for verification.

Non-signaling

Ongoing technological innovation and the ever-rising number of bands that must be supported increase the complexity of state-of-the-art wireless devices. The test effort multiplies, and the production costs rise. For these reasons, finding new, time-saving alignment approaches is essential. Rohde & Schwarz offers a significant reduction of test times compared to conventional methods by

Example of dual test setup

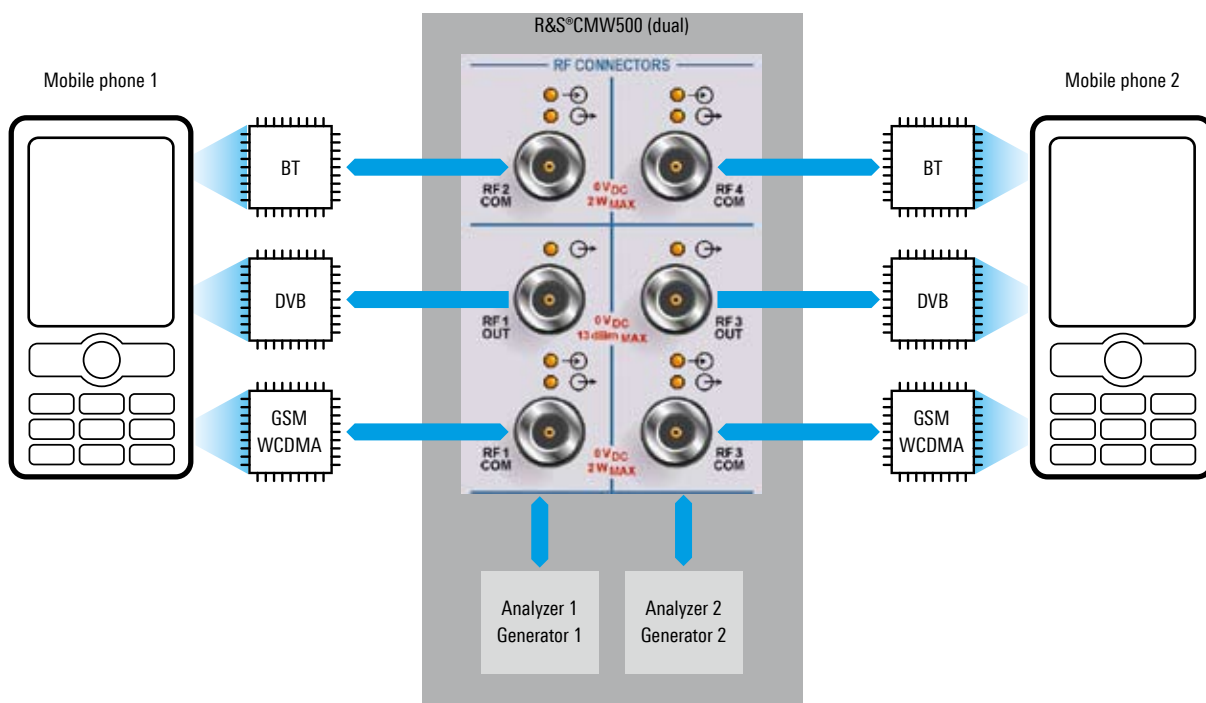

providing R&S®Multi-Evaluation¹⁾ TX measurements and its R&S®Smart Alignment concept. The R&S®CMW500 all-in-one architecture with built-in analyzer and generator provides the fastest possible transmit-receive interaction and is the optimum solution for time-critical tests in production.

R&S®Multi-Evaluation transmitter measurements:

- Different evaluations (power, modulation quality, spectrum, code domain) use an identical sampling data set
- Time-overlapped data capturing and evaluation speed up the measurement
- Enhanced speed by switching off evaluations that are not required

R&S®Smart Alignment and List mode:

- Fully automatic frequency and level switching with general-purpose RF generator and power meter in List mode
- R&S®Multi-Evaluation List mode helps ensure fast transmitter verification
- Simultaneous transmitter and receiver alignment, if supported by the DUT
- Extensive trigger functions for analyzer/generator
- Statistical evaluation included

One cost-efficient ARB signal generator covers all technologies

In the non-signaling mode, a cost-efficient ARB generator instead of a signaling unit makes various downlink signals available early on. Non-signaling measurements with the ARB generator are considerably faster.

Turnkey solution for easy integration into automatic systems

The R&S®CMW500 is a turnkey solution that can start testing immediately after delivery. The fully integrated tester with calibrated RF paths and Press & Go¹⁾ applications simplifies generating and updating test sequences and production test systems. The all-in-one architecture¹⁾ ensures maximum test performance plus minimum footprint and optimum power consumption.

Flexible RF frontend for simple connection with multimode DUTs

The integrated multipoint RF frontend and the built-in power splitter make it easy to distribute signals to various antennas of a DUT or to feed multiple signals to one antenna. They also allow the parallel operation of multiple DUTs.

¹⁾ For explanations, see glossary at end of brochure.

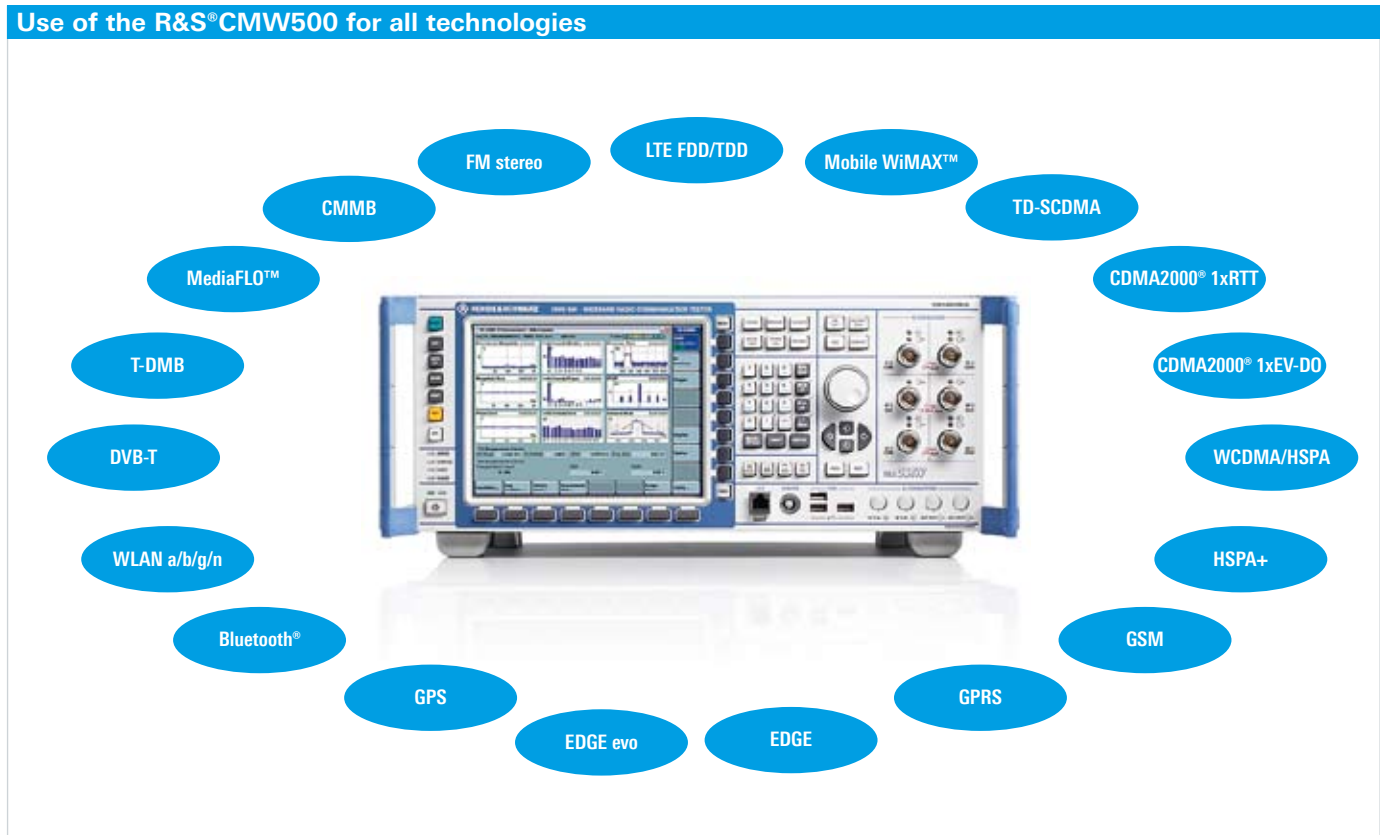

Application

Radio development

Comprehensive suite of RF measurements across multiple technologies

The R&S®CMW500 offers the widest selection of precise RF measurements for wireless devices, including multiple different measurements of the following parameters:

- ▮ Power
- ▮ Modulation quality
- ▮ Spectrum
- ▮ Code domain

The simultaneous display of different measurements on the R&S®Multi-Evaluation screen allows different analyses of the same data sample.

R&S®Multi-Evaluation: LTE TX measurement.

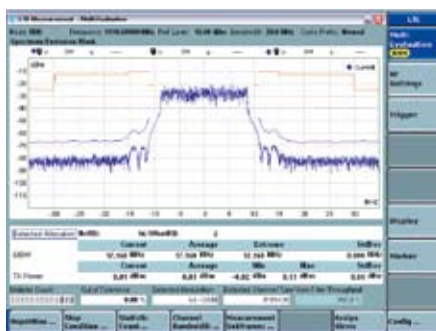
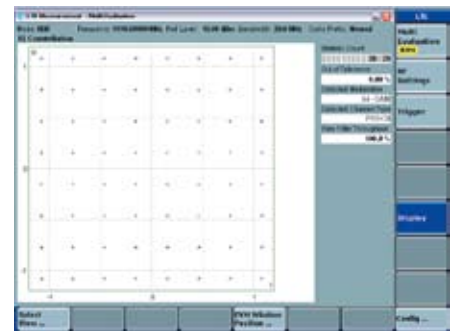
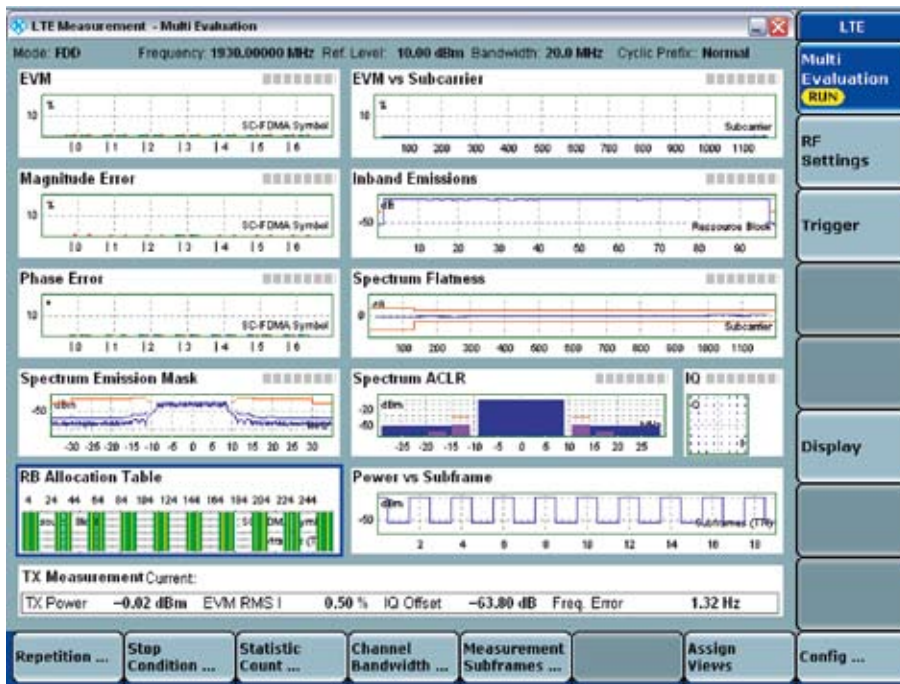

Network emulation with easy callbox operation

Cellular technologies can be executed with automatic protocol stacks to realistically simulate a network with complete signaling. Depending on the technology used, the following procedures are performed, for example:

- Registration
- Call setup (voice, data)
- Intra- and inter-system handover

All signaling parameters are automatically selected by the R&S®CMW500, but the user can modify many of them. Local or remote operation and configuration of the network emulation are performed interactively via the user interface of the R&S®CMW500. All L3 messages can be written down and analyzed with the message analyzer tool.

High accuracy

Excellent state-of-the-art RF hardware ensures high repeatability, linearity and absolute accuracy of the measurements. The built-in temperature sensor, for example, compensates accuracy deviations caused by fluctuating ambient temperature.

Application Protocol development

Comprehensive and detailed LTE (FDD/TDD) and HSPA+ protocol testing is possible, including inter-RAT handover to GSM, WCDMA and 1xEV-DO in line with 3GPP Rel. 7 specifications TS 25.211, TS 25.212, TS 25.213 and TS 25.214, as well as 3GPP Rel. 8 specifications TS 36.302, TS 36.321, TS 36.322, TS 36.323 and TS 36.331.

Reference implementation from L1 to NAS and U-plane protocols

The R&S®CMW500 contains a complete reference implementation of the protocol layers that are required for analyzing the air interface. The configuration and the dynamic behavior of the layers are defined by 3GPP test cases or user-definable test scenarios. This allows any signaling scenarios to be tested and reproduced. New features from the 3GPP specification are immediately included in the stack to make them available for the development of wireless devices.

LTE handover in an R&S®CMW500

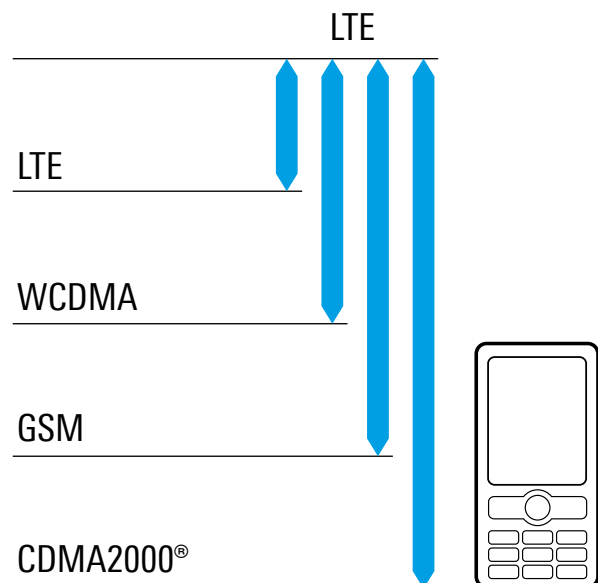

Comprehensive software tools for efficient work

Tried-and-tested software tools enable the user to perform every work step easily and efficiently.

- Project explorer, test case explorer – test campaign management
- Message analyzer – detailed signaling message analysis
- Message composer – easy creation or modification of L3 signaling messages
- Microsoft Visual Studio with R&S®MLAPI libraries – powerful programming interface for defining user-specific signaling scenarios
- Protocol test monitor – online view into the protocol stack state and performance
- Automation manager – easy remote control of DUTs

Sophisticated test scripting with medium-level API (MLAPI) using automatic lower layer configuration

By using the MLAPI programming libraries, the R&S®CMW500 considerably simplifies the definition of user-specific signaling scenarios. MLAPI is an easy-to-operate yet flexible method for generating signaling scenarios.

MLAPI automatically configures the lower layers using the contents of the L3 messages. As a result, the user is largely spared the effort of generating the scenarios. Nevertheless, the user can select and modify functions and parameters as required. The contents of the L3 messages are conveniently generated by means of the message composer tool and afterwards included in the test program. As a result, messages do not have to be recompiled if their contents are changed.

Extensive library with preconfigured messages and signaling scenarios for speeding up test development

To simplify the generation of signaling scenarios even more, Rohde&Schwarz offers over 100 ready-to-run scenarios derived from the collaboration with wireless device developers. These scenarios can be used as they are or as templates for expansions or changes. They are continuously being enhanced and adapted to the current features.

RF/L1 analysis combined with signaling tests

The combination of RF/L1 analysis and user-definable signaling scenarios increases the test depth. The protocol test monitor tool provides detailed insight into the protocol stack. RF measurements show how L3 messages affect the lower layers.

Specifications in brief	
LTE	
Mobile category	4 (150/50 Mbit/s)
MIMO	2 × 2 (4 × 2) ¹⁾
U-plane support	included
Mode	FDD/TDD
Procedures	call establishment, mobility, inter-RAT handover
HSPA+	
Mobile category	up to 14
MIMO	2 × 2
Modulation	QPSK, 16QAM, 64QAM

¹⁾ Future versions.

Application

RF conformance testing

The R&S®TS8980 family of test solutions suits the requirements of the entire wireless device development life cycle. The test systems offer the functionality for development testing up to conformance tests for the certification of wireless devices.

Key facts

- LTE RF conformance test cases in line with 3GPP Rel. 8 specifications TS36.521-1 and TS36.101
- Software upgradeable to WCDMA Rel. 7 RF conformance test cases in line with 3GPP TS34.121-1 and TS34.108 in a future release
- Upgradeable to LTE RRM test cases in line with 3GPP Rel. 8 specification TS36.521-3
- Test applications for development of LTE wireless devices
- Open programming interfaces that support customer-specific application development
- Support of 3GPP-defined LTE bandwidths from 1.4 MHz to 20 MHz and all 3GPP frequency bands up to 6 GHz
- User-friendly R&S®CONTEST tools
- Fully automated execution of test plans
- Convenient reporting functionality
- Scalable system configurations from benchtop setups to rack-integrated systems

RF conformance test setup in different configurations



R&S®CMW500

R&S®TS8980 R&D TX setup

R&S®TS8980 RX/TX setup

R&S®TS8980 FTA full-conformance test system

R&S®TS8980 test system family

Support by means of R&S®CONTEST test environment

Recommended extra R&S®CMWrun sequencer software tool

The R&S®CMWrun sequencer software tool meets all needs for executing test sequences to remote-control the R&S®CMW500 in R&D, quality assurance and in the production of current and future wireless equipment.

The software engine is based on the execution of test DLLs (plug-in assemblies). This architecture not only allows easy and straightforward configuration of test sequences without knowledge of specific remote programming of the instrument. It also provides full flexibility in configuring parameters and limits of the test items provided in the R&S®CMWrun package options for the different standards.

Highlights

- Multitechnology solution
 - R&S®CMWrun general-purpose software package for non-signaling applications (R&S®CMW-KT051 option)
 - R&S®CMWrun WiMAX™ software package for Mobile WiMAX™ in non-signaling and signaling applications (R&S®CMW-KT057 option)
 - R&S®CMWrun sequencer software tool, GSM and WCDMA applications (R&S®CMW-KT053 option)
 - R&S®CMWrun sequencer software tool, CDMA2000® 1xRTT/1xEV-DO applications (R&S®CMW-KT058 option)
 - R&S®CMWrun sequencer software tool, LTE (R&S®CMW-KT055 option)
- Ready-to-use solution, containing predefined Rohde&Schwarz applications for the technologies supported by the R&S®CMW500/280
- Application programming interface (API)-based engine for easy and flexible integration of new applications
- Ease of use due to dedicated interfaces for operation, for editing sequences, for measurement reports and for debugging test sequences
- Application for SCPI remote control via LAN or GPIB interface

Ready-to-go solution with intuitive test plan configuration for different technologies.

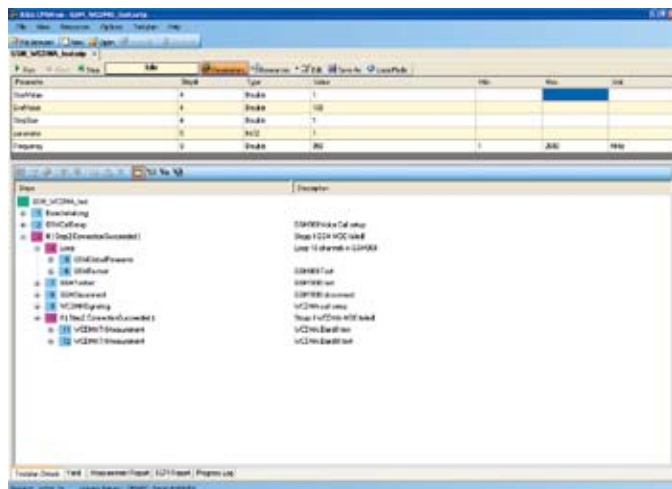

Straightforward display of signaling test reports with R&S®CMWrun.

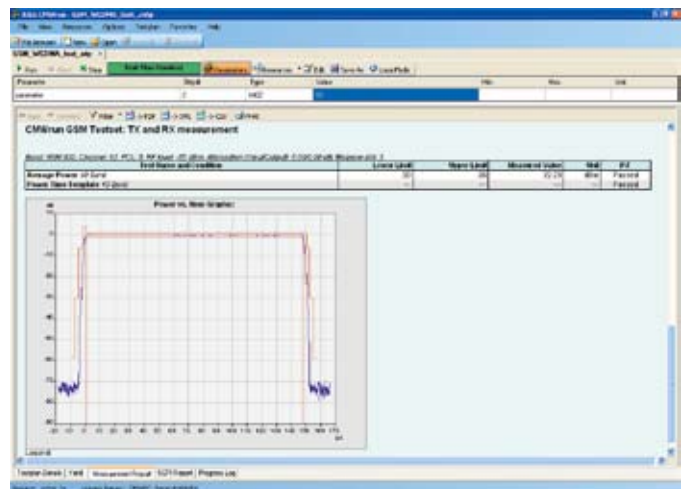

Glossary

Term	Explanation
3GPP	3rd generation partnership project
Alignment	Wireless device production cycle consisting of calibration and verification
All-in-one architecture	Complete, highly integrated compact solution with assured measurement accuracy and optimum handling
API	Application programming interface
ARB	Arbitrary waveform generator
Calibration	Wireless device production stage during which the transmit power steps and the RSSI steps are measured and compared to reference values. The correction factors obtained are stored in the wireless device. Other common designations: phasing, tuning, alignment
CW	Continuous wave
DUT	Device under test
FDD	Frequency division duplexing
GCF	Global Certification Forum
GPS	Global positioning system
I/Q	In-phase and quadrature
LAN	Local area network
LTE	Long-term evolution
NAS	Non-access stratum
Press&Go	Turnkey, highly automated test functionality that is available at the press of a button
PTCRB	PCS Type Certification Review Board

Term	Explanation
R&S®Multi-Evaluation	Transmitter measurement concept where different measurement parameters use identical raw data
R&S®Smart Alignment	Alignment concept where predefined identical test sequences in the DUT and in the tester reduce the data volume in the test system and significantly shorten the test time
R&S®Multi-Evaluation List mode	R&S®Smart Alignment method; fast TX verification based on predefined test sequences
RAT	Radio access technology
RF	Radio frequency
RRM	Radio resource management
R & D	Research and development
TDD	Time division duplexing
Verification	Wireless device production stage during which the most important transmit and receive parameters are checked after calibration
WiMAX™	Worldwide interoperability for microwave access
WLAN	Wireless local area network

Further information

Product brochures with further information and data sheets with complete specifications are available under the order number listed in the table and at www.rohde-schwarz.com.

Title of printed material	Order No. of printed material
Product brochures	
R&S®CMW500 Wideband Radio Communication Tester – RF production testing	PD 5213.9211.12
R&S®CMW500 Wideband Radio Communication Tester – UMTS LTE protocol testing	PD 5213.9363.12
R&S®TS8980IB RF Conformance Test System – Integrated test system for LTE conformance tests	PD 5214.2962.32
Data sheets	
R&S®CMW500 Wideband Radio Communication Tester – Specifications	PD 5213.9211.22
R&S®CMW500 user interface tools – Features and functions	PD 5214.1066.22
R&S®CMW500 WCDMA/HSPA+ protocol test – Features and functions	PD 5214.2385.22
R&S®CMW500 UMTS LTE protocol test – Features and functions	PD 5213.9363.22

Service you can rely on

- | Worldwide
- | Local and personalized
- | Customized and flexible
- | Uncompromising quality
- | Long-term dependability

About Rohde & Schwarz

Rohde & Schwarz is an independent group of companies specializing in electronics. It is a leading supplier of solutions in the fields of test and measurement, broadcasting, radiomonitoring and radiolocation, as well as secure communications. Established 75 years ago, Rohde & Schwarz has a global presence and a dedicated service network in over 70 countries. Company headquarters are in Munich, Germany.

Environmental commitment

- | Energy-efficient products
- | Continuous improvement in environmental sustainability
- | ISO 14001-certified environmental management system

Certified Quality System
ISO 9001

Rohde & Schwarz GmbH & Co. KG

www.rohde-schwarz.com

Regional contact

- | Europe, Africa, Middle East
+49 89 4129 137 74
customersupport@rohde-schwarz.com
- | North America
1 888 TEST RSA (1 888 837 87 72)
customer.support@rsa.rohde-schwarz.com
- | Latin America
+1 410 910 79 88
customersupport.la@rohde-schwarz.com
- | Asia/Pacific
+65 65 13 04 88
customersupport.asia@rohde-schwarz.com

R&S® is a registered trademark of Rohde & Schwarz GmbH & Co. KG
Trade names are trademarks of the owners | Printed in Germany (ch)
PD 5214.2833.12 | Version 01.00 | December 2009 | R&S®CMW500
Data without tolerance limits is not binding | Subject to change
© 2009 Rohde & Schwarz GmbH Co. KG | 81671 München, Germany